



Truma Combi*

LP Gas Furnace with Supplementary Indirect Water Heating

⚠ WARNING

FIRE OR EXPLOSION HAZARD

Failure to follow safety warnings exactly could result in serious injury, death or property damage.

Do not store or use gasoline or other flammable vapors and liquids in the vicinity of this or any other appliance.

WHAT TO DO IF YOU SMELL GAS

- Evacuate all persons from the vehicle.
- Shut off the gas supply at the gas container or source.
- Do not touch any electrical switch, or use any phone or radio in the vehicle.
- Do not start the vehicle's engine or electric generator.
- Contact the nearest gas supplier or certified service technician for repairs.
- If you cannot reach a gas supplier or certified service technician, contact the nearest fire department.
- Do not turn on the gas supply until gas leaks have been repaired.

Installation and service must be performed by a qualified installer, service agency, or the gas supplier.

Operating instructions

To be kept in the vehicle.
This document is part of the furnace.



Conforms to ANSI Std. Z21.47
Certified to CSA Std. 2.3

* Patent Pending



Table of Contents

Trademark information	2
Intended use	2
Prohibited use	2
Mounting arrangement / Accessories	3
Furnace diagram	4

Consumer Safety Information

Safety symbols and signal words	6
Safety behavior and practices	6
Safety features	8

Operating Instructions

How the Combi furnace works	8
Selectable modes of operation	9
Selectable modes of power input	9
Switch for gas shut-off valve	10
Room temperature sensor	10
Truma pressure relief/drain valve	10
Opening the Truma pressure relief/drain valve	11
Closing the Truma pressure relief/drain valve	11
Starting the Combi furnace	11
Inspections before each use	11
Filling the water container	12
Switching on the furnace	12
Shutdown	13
Switching off the furnace	13
Draining the water container	13
Winterizing	14
Optional: Winterizing the RV with a winterizing fluid	14
Winter operation	14
Combi Technical Data	15
“Combi” MANUFACTURER’S LIMITED WARRANTY	16
Maintenance and service	17
Decalcifying and cleaning the water container	17
Truma pressure relief/drain valve	18
Replacing the 12-volt fuse	18
Troubleshooting	19
Appendix	20

California Proposition 65 lists chemical substances known to the state to cause cancer, birth defects, death, serious illness or other reproductive harm. This product may contain such substances, be their origin from fuel combustion (gas) or components of the product itself.

Trademark information

Truma Combi referred to as Combi below.

Intended use

The Combi LP gas furnace* with supplementary indirect water heating may be used only in recreational vehicles (RVs) for heating the room and the faucet water.

Recreational vehicles (RVs) are designed as temporary living quarters for recreation, travel and/or camping. RVs have their own power or are towed by another vehicle.

*Models

- Combi eco
- Combi eco plus
- Combi comfort
- Combi comfort plus

The Combi eco plus and Combi comfort plus furnaces also feature electrical heating elements for a supply voltage of 120 V.

Prohibited use

Any use other than the intended use (see above) is prohibited.

Examples of prohibited use:

- Use in a marine environment.
- Use as part of a space heating system.
- Use in mobile homes.
- Use in food trucks or roadside food vending vehicles.
- Use in construction trailers.

Mounting arrangement / Accessories

i This is a typical installation for illustration. The installation in your vehicle may vary. The illustration is not to scale.

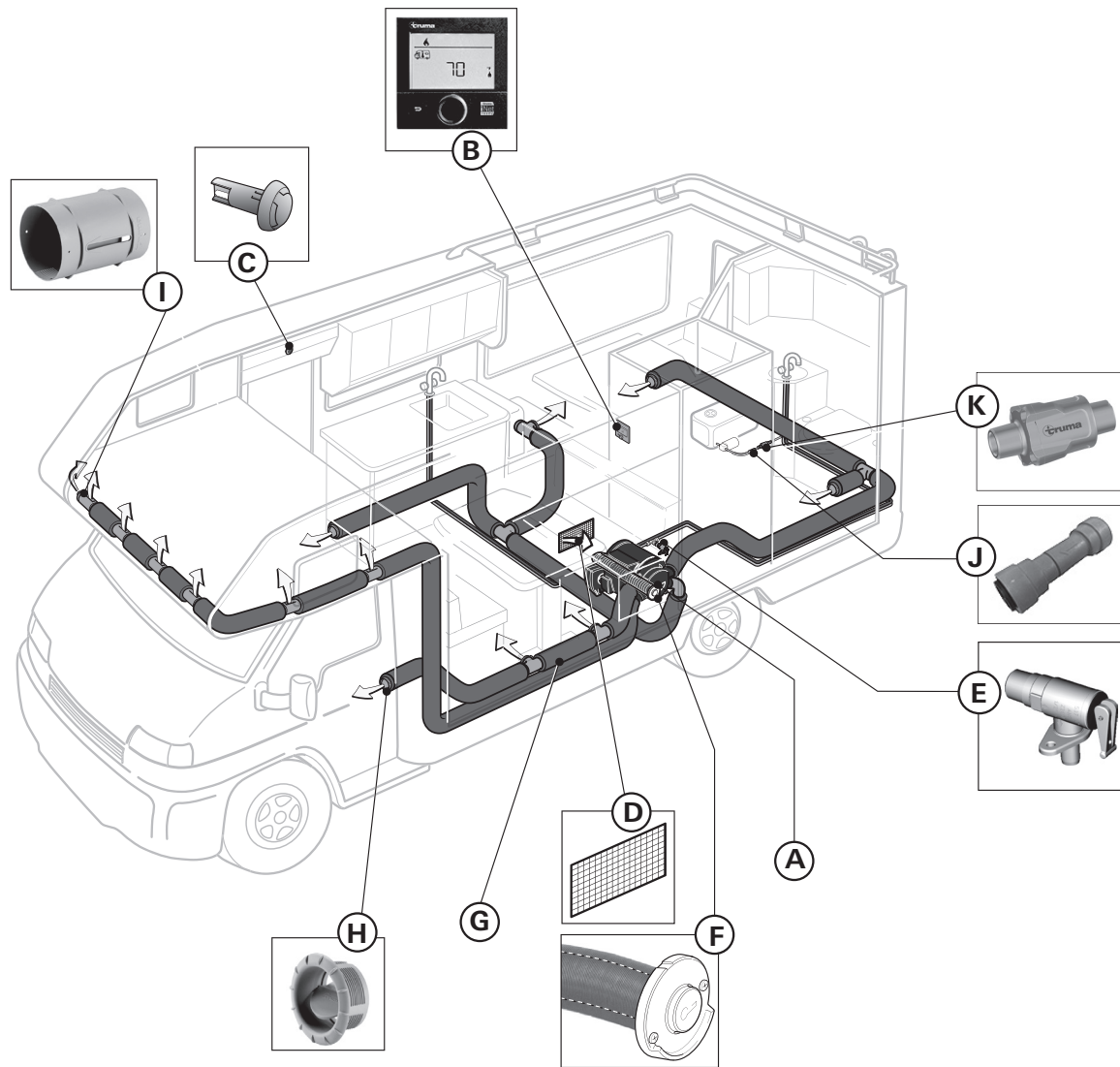

Fig. 1

Legend

- | | |
|---|---|
| A Combi furnace | G Warm air ducts with insulation sleeve |
| B CP plus control panel | H Warm air end outlet with air throttle |
| C Room temperature sensor | I Wall outlet vent |
| D Opening for circulated air intake (with mounted grid) | J Non-return valve |
| E Truma pressure relief/drain valve | K Truma water pressure regulator |
| F Wall cowl with exhaust venting system (tube in tube) | |

Furnace diagram

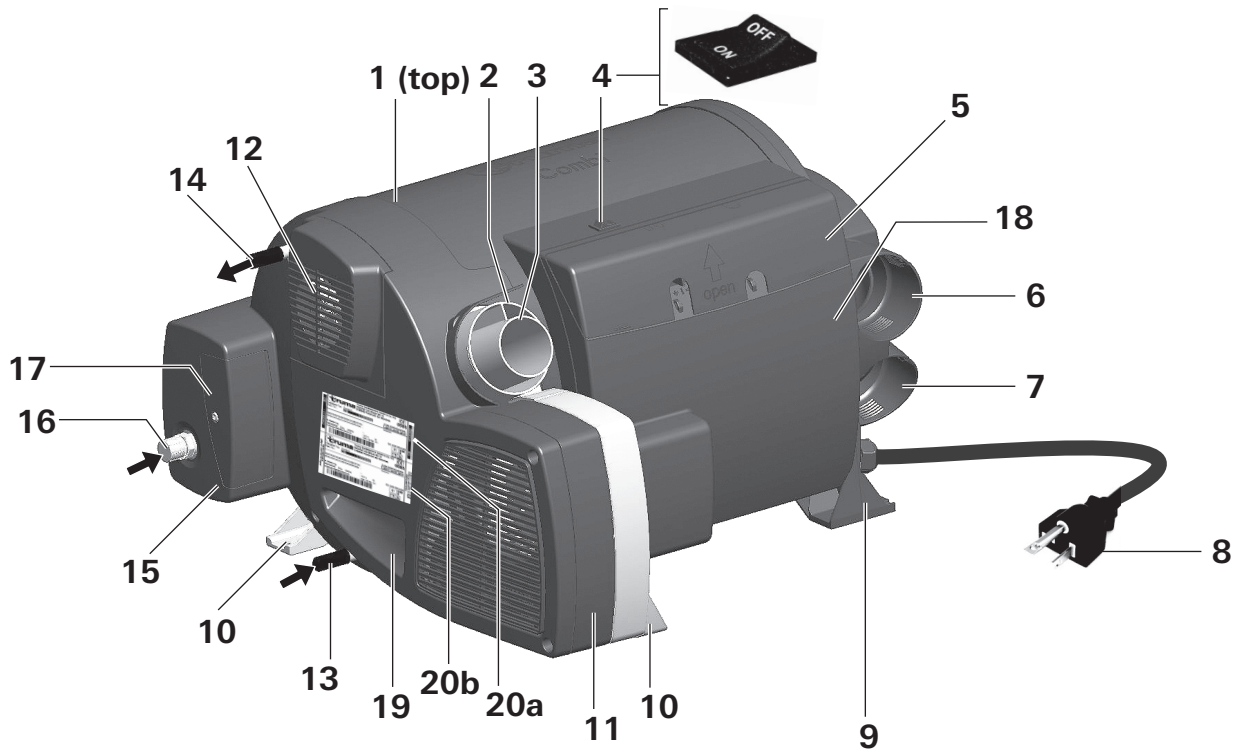

Fig. 2

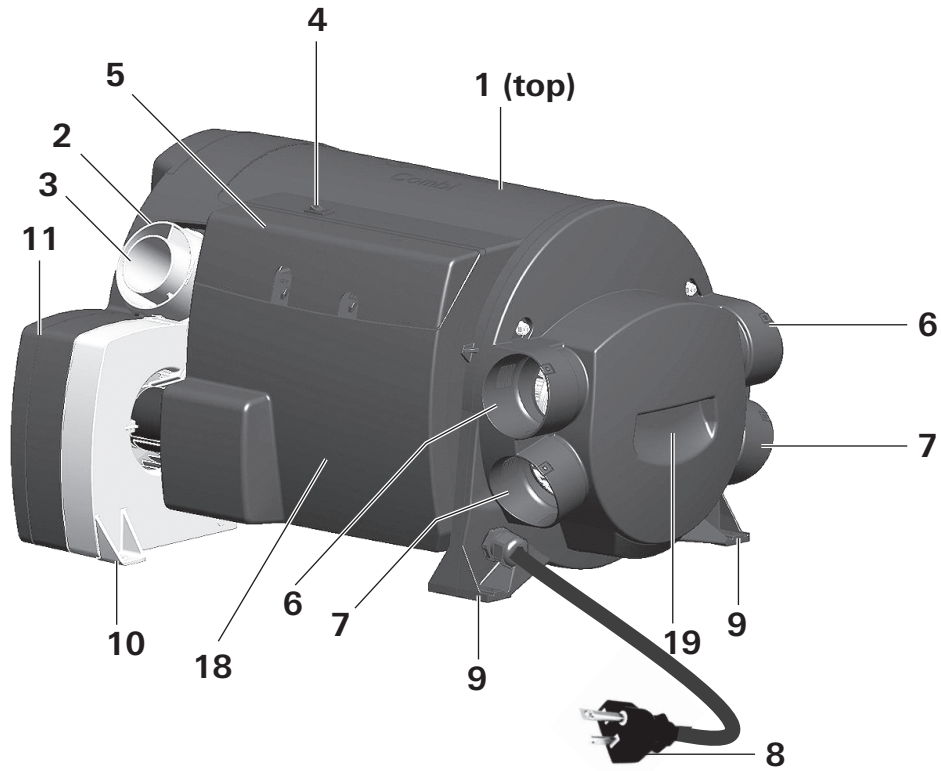



Fig. 3

Key

- 1 Combi furnace with supplementary indirect water heating
- 2 Connection for combustion air supply tube
- 3 Connection for exhaust tube
- 4 Switch for gas shut-off valve
- 5 Connection cover
- 6 Warm air outlets (upper)
- 7 Warm air outlets (lower)
- 8 2-pole, 3-wire 120 volt electrical plug (only on Combi eco plus and Combi comfort plus models)
- 9 Plastic frame feet
- 10 Aluminum frame feet
- 11 Circulated air fan
- 12 Fan for combustion air
- 13 Cold water connection (inlet)
- 14 Hot water connection (outlet)
- 15 Gas shut-off valve (behind the cover)
- 16 Gas connection (inlet)
- 17 Test connection (gas) (behind the cover)
- 18 Electronics housing cover
- 19 Recessed grips
- 20a Original type plate
- 20b Duplicate type plate

Consumer Safety Information

Safety symbols and signal words

 This is the safety alert symbol. This symbol alerts you to potential hazards that can kill or hurt you and others.

DANGER indicates a hazardous situation which, if not avoided, will result in death or serious injury.

WARNING indicates a hazardous situation which, if not avoided, could result in death or serious injury.

CAUTION indicates a hazardous situation which, if not avoided, could result in minor or moderate injury.

NOTICE is used to address practices not related to physical injury.

 Other important information or tips

Safety behavior and practices

Ensuring a safe operating environment

- **Danger of suffocation!** To ensure dissipation of exhaust gases, operate the Combi furnace outdoors only.
 - Never use in enclosed spaces or tents or breathe in the exhaust gases.
 - If installing an airtight awning, make sure that the exhaust system terminates outdoors.
 - If the RV is parked in an enclosed space:
 - Block the flow of fuel to the Combi furnace.
 - Deactivate the time switch.
 - Switch off the Combi furnace at the control panel.
 - Ensure that the Combi furnace cannot be switched on through the Truma App under any circumstances.
- Use the Combi furnace only with a functional LP gas and carbon monoxide detector installed in the RV. For installation, operation and function test follow the manufacturer's guidelines.

- Keep the area around the Combi furnace free from combustible materials, gasoline, and other flammable vapors or liquids such as pressurized dispensers or wax candles.
- Keep the area in front of the warm air outlets (Fig. 1 – H) free of combustible or heat-sensitive materials. Do not put any material into the warm air outlets.
- In order to avoid overheating of the Combi furnace, keep the air inlets of the Combi furnace (Fig. 2 – 11), the air openings to the area in which the Combi furnace is installed (Fig. 1 – D) and the spacing around the Combi furnace free of obstruction.
- To ensure clean combustion, keep the wall cowl free of obstruction. Do not lean any objects against the wall cowl (Fig. 1 – F).
- **WARNING**
CARBON-MONOXIDE POISONING HAZARD!
Failure to follow instructions could result in severe personal injury or death due to carbon-monoxide poisoning, if combustion products enter the RV.

Check that all openings in the outside wall around the vent (and air intake) pipe(s) are sealed to prevent combustion products entering the RV.

Check that furnace vent (and air intake) terminal(s) are not obstructed in any way during all seasons.

- Danger of hot surfaces. The temperature of the exhaust gases can reach 320 °F (160 °C). Do not touch the area around the wall cowl and do not lean any objects against the wall cowl or the RV.

Responsibilities of the operator

- The operator is responsible for the water filled into the Combi water container and its quality.
- The operator is responsible for protecting the Combi furnace against freezing.

Safe operation

- Use with LP gas (propane) only. Butane or any mixtures containing more than 10 % of butane must not be used.
 - LPG tanks must be filled by a qualified gas supplier only.

- Danger of damage to the gas system! For the operation of gas pressure regulation systems, gas-burning devices or gas systems only gas cylinders that supply gas in the gaseous phase may be used. Gas cylinders which supply gas in the liquid phase are prohibited.
- During the initial start-up of a brand new appliance, small quantities of fumes and a slight odor may occur briefly. When the appliance is started up after a particularly long period of non-use, there may be some smoke and/or smell due to dust or dirt. It is a good idea to allow the appliance to run at maximum output for a few minutes and to ensure that the area is well ventilated.
 - For using the Combi furnace in hot water mode (140 °F (60 °C)), let it heat up several times.
- Hot air can be dangerous, especially for infants, children, the elderly, or infirm. It can cause burns:
 - Ventilation air can reach 250 °F (121 °C) at the warm air outlets. Always check the air temperature before varying the air throttle position (Fig. 1 – H).
- Hot water can be dangerous, especially for infants, children, the elderly, or infirm. It can cause severe burns:
 - Never actuate the pressure relief/drain valve (Fig. 1 – E) as long as the Combi furnace is under water pressure and/or still hot.
 - Always check the water temperature before entering a shower or bath.
- How long before hot water causes skin damage?
- Children up to 17 years of age as well as people with physical, sensory, or mental disabilities and/or people who are inexperienced or unknowledgeable may use the Combi furnace only if they are supervised or have been instructed in the safe use. They must also understand the risks associated with using it. Children must not play with the Combi furnace.

Safe operation while moving the RV

- Shut OFF gas and the LPG tank when moving the RV. This disables all gas appliances and pilot lights. Gas appliances must never be operated while vehicle is in motion.
- Shut OFF the Combi furnace when refueling or pumping gas.
- To avoid damage, make sure no spray water enters the Combi furnace when cleaning the RV, e.g., do not spray directly into the wall cowl.

Safe handling of malfunctions

- Switch OFF the gas supply and the Combi furnace if anything seems to be out of the ordinary.
- Danger of fire or explosion when attempting to use a flood-damaged Combi furnace or if the RV has been involved in an accident! A qualified service technician must inspect the furnace. In the case of moisture damage, the qualified service technician must replace damaged gas controls, control system parts and/or electrical parts, or provide a new furnace.
- Only a qualified service technician may perform repairs.
- Have a qualified service technician immediately remedy any malfunctions.
 - Remedy a malfunction yourself only if a remedy is specified in the troubleshooting chart in these operating instructions (refer to “Troubleshooting” on page 19).
- After any misfire, a qualified service technician must inspect the Combi furnace and the exhaust tube.

Temperature °F (°C)	Time before skin becomes scalded
155 (68)	1 second
148 (64)	2 seconds
140 (60)	5 seconds
133 (56)	15 seconds
127 (52)	1 minute
124 (51)	3 minutes
120 (48)	5 minutes
100 (37)	safe bathing temperature

Source: Moritz, A.R. / Hérriques, F.C.: Studies of thermal injuries: the relative importance of time and surface temperature in causation of cutaneous burns
A. J. Pathol 1947; 23: 695 - 720

Safe maintenance and repair

- Only a qualified service technician may clean and maintain the furnace.
- Any alteration to the Combi furnace or its controls can cause unforeseen serious hazards and will void the warranty.
- After a long period of winterizing: Flush all hot/cold water hoses and the Combi furnace thoroughly with drinking water before using it.

Safety features

The Combi furnace is equipped with the following safety devices:

Switch for gas shut-off valve

The switch (Fig. 2 – 4) shuts off the power to the safety gas valve and the gas supply to the furnace. If you want to make sure that the gas supply to the furnace is off, turn the switch to the OFF position.

Flame monitoring

If the flame goes out, the gas supply is switched off.

Low-voltage shut down

If the voltage drops below 10 VDC, the gas supply is switched off.

Overcurrent protection

If there is a short circuit in the Combi furnace (>10 A), a fuse on the control unit is activated and the Combi furnace is switched off.

Monitoring of hot water temperature

A water over temperature switch avoids excessively high water temperatures.

Monitoring of hot air temperature

An air over temperature switch avoids excessively high air temperatures.

Operating Instructions

Read and follow the “Consumer Safety Information” before operating the Combi furnace.

NOTICE **Danger of faulty operation!**
Always use the CP plus control panel to operate the Combi furnace. Operating instructions are supplied with the CP plus control panel.

▲ WARNING

Scalding injuries caused by hot water!

Water temperatures over 127 °F (52 °C) can cause severe burns or scalding and in extreme cases even death.

Water in the hot water container can become as hot as 162 °F (72 °C) during operation. If there is a malfunction, the water can reach 205 °F (96 °C).

- Always use potable water to fill the hot water container. The person operating the furnace is responsible for the quality of this water.
- Before using a hot water faucet or using the shower, allow the hot water to run until the water temperature no longer increases and mix with cold water.
- Test the temperature of the water before placing a child in the bath or shower.
- Do not leave a child or an infirm person in the bath unsupervised.

How the Combi furnace works

The Combi furnace was developed exclusively for use in recreational vehicles (RVs). The Combi is a furnace with a supplementary, indirect hot water generator.

All Combi models are powered by propane and a 12 V power supply.

The Combi eco plus and Combi comfort plus models are also powered by electrical heating elements for operation at a supply voltage of 120 VAC.

Room air is drawn into the furnace by a fan, heated up and conveyed via flexible ducts to the RV's interior.

The Combi furnace with supplementary water heating is installed between the RV's fresh water supply line and its hot water system.

A comfortable water temperature at the shower head is reached by mixing in cold water.

A wall cowl allows combustion air to flow into the furnace and exhaust gas to flow out. The wall cowl and the furnace are connected by a tube in the tube exhaust venting system: an exhaust tube inside and a combustion air intake tube outside.

NOTICE Damage to the Combi furnace caused by freezing! The Combi furnace does not have a frost-protection function. If the heating is not used and there is a risk of freezing, all water must be drained from the water container (refer to "Draining the water container" on page 13).

Selectable modes of operation

The CP plus control panel (Fig. 1 – B) is used to switch between modes of operation (refer to the CP plus manual for additional instructions).

1. Heating mode

The furnace automatically selects the proper operating level based on the difference between the desired temperature set at the control panel and the current room temperature. If there is any water in the water container, it will be heated automatically. The water temperature will not be regulated, but it will reach a maximum of 162 °F (72 °C).

2. Hot water mode

(only if water container contains water)
Hot water mode is ideal if only hot water is required. The lowest burner setting suffices for heating water. In hot water mode, the burner will switch off as soon as the water reaches the temperature selected in the CP plus control panel.

Both modes of operation can be combined.

Selectable modes of power input

The CP plus control panel is used to select various modes of energy for the Combi eco plus and Combi comfort plus models.

No Combi furnace operates in any mode without a 12 VDC power supply.

1. LP gas for gas mode

All Combi furnaces run on LP gas (propane).

2. Electricity for electric mode

The Combi eco plus and Combi comfort plus furnaces can be powered by electricity if the RV is connected to a mains power supply or a generator.

NOTICE Only a 120 V sine-wave-generator may be used to avoid damage to the Combi.

3. LP gas and electricity (mixed mode)

The Combi eco plus and Combi comfort plus furnaces run simultaneously on LP gas (propane) and electricity.

If the selected **operating mode** is:

1. Heating mode:

The Combi eco plus and Combi comfort plus run simultaneously with LP gas (propane) and electricity.

2. Hot water mode:

The Combi eco plus and Combi comfort plus run in electric mode with a preselected power output setting of 850 W (Mix 1) or 1700 W (Mix 2).

When the RV is disconnected from the power supply*, the furnace will automatically switch to LP gas (propane).

* With sufficient supply of 12 V DC and LP gas (propane).

Switch for gas shut-off valve

The switch (Fig. 4) shuts off the power to the safety gas shut-off valve and with this the gas supply to the Combi furnace. To make sure that the gas supply to the furnace is off, turn the switch to the OFF position.

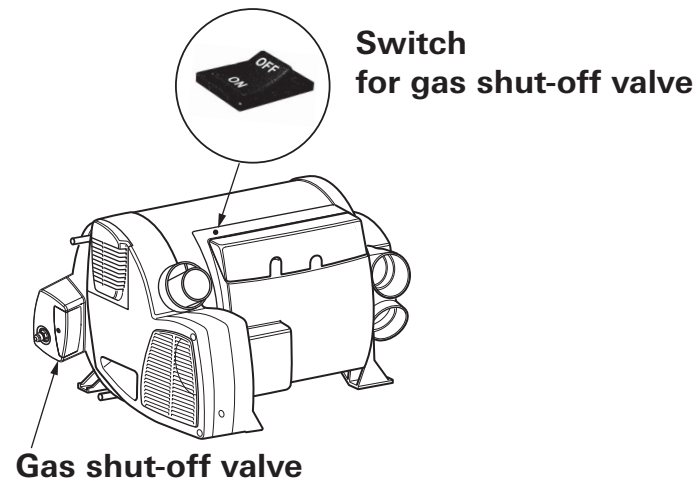

Fig. 4

Switch positions of the switch for gas shut-off valve:

- Off = gas shut-off valve is closed
- On = gas shut-off valve is open

Room temperature sensor

A room temperature sensor (Fig. 1 – C) measures the temperature inside the RV.

The installation location for the room temperature sensor depends on the RV and will be chosen by the RV manufacturer.

Truma pressure relief/drain valve

⚠ WARNING

Risk of scalding injury from hot water and/or tampering with the pressure relief/drain valve!

- Never actuate the pressure relief/drain valve as long as the Combi furnace is still hot.
- Do not place a plug or reducing coupling on the outlet part of the valve. If you use a discharge line, allow the valve and the line to drain completely.



- The Truma pressure relief/drain valve provides both the pressure relief function and a drain function.
- The pressure relief/drain valve is a safety component and must not be removed for any reason other than replacement.
- The pressure relief/drain valve is not serviceable; if defective, it must be replaced. It must be replaced by a certified service technician.
- It must only be replaced by the Truma pressure relief/drain valve rated for 65.25 psi (4.5 bar) which is CSA certified and registered.
- Tampering with the pressure relief/drain valve will void the warranty.

The Combi furnace with supplementary indirect water heating must be installed with the Truma pressure relief/drain valve (Fig. 5) that complies with the standard for Relief Valves for Hot Water Systems, ANSI Z21.22.

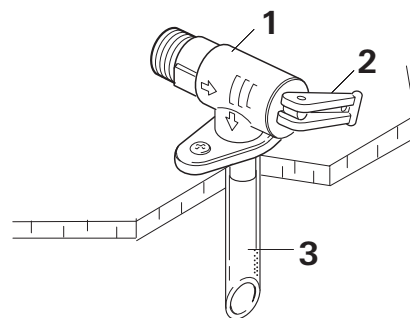

Fig. 5

- 1 Truma pressure relief/drain valve
- 2 Lever
- 3 Drainage socket (extends through RV's undercarriage to outside)

Opening the Truma pressure relief/drain valve

NOTICE Danger of damage to the Combi and the RV due to an obstructed drainage socket! The drainage socket (Fig. 5 – 3) must be unobstructed and kept clear of obstructions such as slush, ice, or leaves to ensure that water can drain properly. No warranty claims for frost damage will be accepted.

- Move the lever so that it is in the “draining” position (Fig. 6 – c). Water will drain from the hot water container via the drainage socket (Fig. 5 – 3).

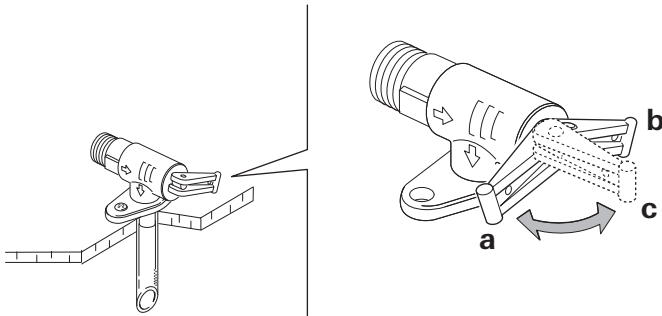

Fig. 6

- a,b = lever in “valve closed during furnace operation” position
c = lever in “draining” position

Closing the Truma pressure relief/drain valve

- Move the lever so that it is in the “closed” position (Fig. 6 – a or 6 – b)

Starting the Combi furnace

▲ WARNING

Danger of over-temperature and toxic exhaust gases!

- Use with LP gas (propane) only. Butane or any mixtures containing more than 10 % of butane must not be used.
- Keep the air inlet and exhaust gas outlet free of obstructions. Do not lean any objects against the wall cowl on the RV or place any objects within a range of 2 feet (61 cm) of the wall cowl.

▲ WARNING

Danger of combustion and damage to persons and the RV!

- Keep the area around the Combi furnace free from combustible materials, gasoline, and other flammable vapors or liquids.
- Switch the gas supply and the Combi furnace off:
 - if anything seems to be out of the ordinary.
 - if you smell gas.
 - if you move the RV.
 - before entering a gas station.
 - before entering a tunnel.
 - before entering a ferry boat.

Inspections before each use

Check the Combi furnace for the following points before each use. In case of damage, contact an authorized Truma service provider and do not operate the Combi furnace.

- Inspect the furnace (Fig. 1 – A), exhaust venting system (Fig.1 – F), and wall cowl (Fig.1 – F) for damage. Verify that connections are tight and fasteners are secure.
- The wall cowl (Fig. 1 – F) for drawing in combustion air and emitting exhaust must be free from obstructions such as slush, ice or leaves. The furnace will not function properly if the combustion-air inlet or exhaust tube is partially or completely obstructed.

- The warm air outlets (Fig. 1 – H), the wall outlet vents (Fig. 1 – I) and the openings for the circulated air intake (Fig. 1 – D and Fig. 2 – 11) must be free from obstructions to ensure that the furnace functions properly. Any obstructions might cause the furnace to overheat. If this happens, the built-in temperature limiter will interrupt the flow of gas to the furnace. Once the furnace has cooled, it will switch on again automatically.
- Access to adequate quantities of LP gas (fuel inlet pressure 11 – 13 in. wc (27.4 – 32.4 mbar)) and 12 V power must be available.

The Combi eco plus and Combi comfort plus models

- Make sure that the supply voltage's fuse protection of the campground suffices for operating the furnace in electric mode. The furnace needs up to 1,700 W (14.2 A) in operating mode 2. If the supply voltage's fuse protection is not sufficient, the furnace can be operated in operating mode 1 with up to 850 W (7.1 A).

NOTICE Danger of damage to the power cord due to overheating! If you use an extension cord on a cable drum to connect the RV to the campground power system, make sure the cord is fully extended.

Filling the water container

NOTICE Damage to the water container! The water pressure on the inlet side must be limited to 40.6 psi (2.8 bar), otherwise internal components of the appliance will be damaged. On (city) water connections with a pressure higher than 40.6 psi (2.8 bar) a pressure regulator is strongly recommended.

1. Close the pressure relief/drain valve, if open (refer to "Closing the Truma pressure relief/drain valve" on page 11).
2. Close open bypass lines, if present.
3. Turn on the fresh water supply or switch on the water pump.
4. Fill the plumbing system:
 - Open all water-release points, e.g. cold and hot water faucets, showers, toilets.
 - Once water flows, the plumbing system is ventilated and filled. Close all water-release points.

Switching on the furnace

i For the furnace to work properly, there must be enough LP gas (propane >11 in. wc) and 12 VDC power. Optionally, for electric or mixed mode with the Combi eco plus and Combi comfort plus, an additional 120 VAC power supply is needed.

1. Switch on the furnace's 12 VDC power supply.
2. If necessary, fill the water container with water (refer to "Filling the water container" on page 12). If no hot water is needed, the Combi furnace can be operated without being filled.
3. Make sure the supply of LP gas is turned on at the tank.
4. Make sure the gas shut-off valve is switched on (refer to "Switch for gas shut-off valve" on page 10).

i Operation without gas supply is possible for the Combi eco plus and the Combi comfort plus. The maximum heating power is then 1,700 W.

5. Use the CP plus control panel to switch on the Combi furnace (refer to the CP plus manual for additional instructions).

▲ WARNING

Scalding injuries caused by hot water!

Water temperatures over 127 °F (52 °C) can cause severe burns or scalding and in extreme cases even death.

- Before using a hot water faucet or using the shower, mix with cold water and allow the hot water to run until the water temperature no longer increases.
- Test the temperature of the water before placing a child in the bath or shower.
- Do not leave a child or an infirm person in the bath unsupervised.



- There may be a variation between the temperature delivered from the Combi furnace and the temperature at the faucet due to water conditions or the length of pipe from the Combi furnace.
 - The presence of a flow restrictor in the hot water line may limit the water flow.
6. If using hot water:
- Use the CP plus control panel to select the desired water temperature level.
 - To obtain the desired water temperature at the faucet or in the shower, mix cold and hot water.
 - Make sure that the water temperature has stabilized before any person or animal enters the shower.

⚠ WARNING**Scalding injuries caused by hot air!**

Ventilation air can reach 250 °F (121 °C) at the warm air outlet and it can cause severe burns or scalding and in extreme cases even death.

- Always check the air temperature before varying the air throttle position (Fig. 1 – H).

7. If using hot air:
- Use the CP plus control panel to set the desired room temperature.

Shutdown

Switching off the furnace

1. Switch off the Combi furnace using the CP plus control panel. Due to internal processes, it may take some time until the furnace is completely shut down.
2. If the Combi furnace and any other gas-powered device is not needed anymore, turn off the LP gas supply.
3. Switch off the Combi furnace's electrical power supply.



If you intend to put the RV into storage or if you switch off the Combi furnace during freezing temperatures, refer to "Winterizing" on page 14.

Draining the water container

NOTICE Damage to the Combi furnace caused by freezing!

- The Combi furnace does not have a frost-protection function. The water container must be drained if the recreational vehicle (RV) will not be used whenever there is a risk of frost.

No warranty claims for frost damage are accepted.



To make sure that all water drains properly from the water container, place a big enough vessel underneath the drainage socket of the pressure relief/drain valve (> 2.64 gallons (10 liters)).

1. Use the main switch or pump switch to switch off the power to the water-pump assembly.
2. Turn off or disconnect the city water connection, if present.
3. Open all water release points, e.g. cold and hot water faucets, showers, toilets.
4. Open the pressure relief/drain valve (refer to "Opening the Truma pressure relief/drain valve" on page 11).

The water container will drain via the drainage socket of the pressure relief/drain valve.

Winterizing

NOTICE Severe damage to the plumbing components and the Combi furnace! Damage due to freezing or an unsuitable winterizing fluid is not covered by warranty.

- Follow the recommendations below if the Combi furnace will be stored under freezing conditions or for an extended period of time.
- Winterize the Combi furnace at the start of the winter season or before traveling to a location where freezing conditions are likely.

For winterizing, drain the Combi furnace, refer to “Draining the water container” on page 13.

After draining the water, the Combi furnace is protected against freezing conditions.

Optional: Winterizing the RV with a winterizing fluid

 Winterizing the RV with a winterizing fluid is only possible with an installed bypass kit (not in scope of supply), refer to the RV manual.

1. Drain the water container (refer to “Draining the water container” on page 13).
2. Turn the valves of the bypass kit according to the supplier’s or RV manufacturer’s guidelines.
3. Flush the water system with a suitable winterizing fluid according to the supplier’s or RV manufacturer’s guidelines.

 Before using the Combi furnace again in hot water mode, remove the winterizing fluid and flush the water system with potable water.

Winter operation

To operate the Combi furnace in potentially freezing conditions, the following requirements must be ensured:

- There must be sufficient LP gas (propane; fuel inlet pressure 11 – 13 in. wc (27.4 – 32.4 mbar)) in the tank.
- In addition, the Combi eco plus and Combi comfort plus models require a supply voltage of 120 V if they are to be operated in electric or mixed mode.
- For hot water operation, the water container must be filled (refer to “Filling the water container” on page 12). You must leave the furnace powered ON whenever freezing might occur.

Winter operation will not protect the RV’s entire plumbing system. The RV must be designed for freezing conditions.

Combi Technical Data

Fuel	LP gas (propane only)
Inlet pressure	11 – 13 in. wc (27.4 – 32.4 mbar)
Manifold pressure	10 in. wc (24.9 mbar)
Duct static pressure	minimum of 0.00 in. wc (0.0 mbar) maximum of 0.65 in. wc (1.6 mbar)
Temperature rise	<150 °F (83 °C)

Energy Input Rate / Gas Consumption

LP gas mode	Operating level 1	Operating level 2	Operating level 3
Combi eco	7,500 BTU/h (2.2 kW)	14,300 BTU/h (4.2 kW)	–
Combi eco plus	5.3 oz/h (150 g/h)	10 oz/h (290 g/h)	
Combi comfort	7,500 BTU/h (2.2 kW)	14,300 BTU/h (4.2 kW)	20,400 BTU/h (6 kW)
Combi comfort plus	5.3 oz./h (150 g/h)	10 oz/h (290 g/h)	14 oz/h (410 g/h)

Electric mode

Combi eco plus	850 W	1,700 W	–
Combi comfort plus			

Mixed mode

	LP gas	+	electric
Combi eco plus (maximum)	7,500 BTU/h (2.2 kW)	+	1,700 W
Combi comfort plus (maximum)	14,300 BTU/h (4.2 kW)	+	1,700 W

Power supply

Power consumption at 12 VDC (DC < 1 Vpp)

Combi eco	transient: max. 6.1 A
Combi eco plus	(average power consumption: approx. 1.6 A)
Combi comfort	transient: max. 6.1 A
Combi comfort plus	(average power consumption: approx. 1.8 A)
Water heating only	max. 0.9 A

Power consumption at 120 VAC / 60 Hz (mains connection or sine wave generator)

	Operating level 1	Operating level 2	Operating level 3
Combi eco plus	7.1 A	14.2 A	–
Combi comfort plus			

Hot Water System

Capacity of water container	2.64 gallons (10 liters)
Water heating time from 59 °F (15 °C) to 140 °F (60 °C)	approx. 23 minutes in hot water mode (measured according to EN 15033)
Water inlet pressure	max. 40.6 psi (2.8 bar)
System operating pressure	max. 65.25 psi (4.5 bar)

Shipping weight (without water and without peripheral equipment)

Combi eco	35.1 lbs. (15.9 kg)
Combi comfort	
Combi eco plus	37.0 lbs. (16.8 kg)
Combi comfort plus	

Truma Gerätetechnik GmbH & Co. KG
("Truma")

"Combi" MANUFACTURER'S LIMITED WARRANTY

(September 2014)

This limited warranty pertains solely to the "Combi" (the "Product") manufactured by **Truma** and sold through its affiliates and dealers in North America.

Truma warrants subject to the below stated conditions that the Product will be free from defects in material and workmanship, and will perform in accordance with the technical specifications set forth in the description of the Product for a period of twelve (12) months for newly manufactured parts from the original date of purchase. The original purchaser is advised to register the Product within two (2) months of purchase at **www.truma.net** in order to receive an extended warranty of an additional twelve (12) months. This limited warranty shall only apply if the Product was properly installed according to the installation instructions provided and in compliance with applicable codes.

During the warranty period, Truma will repair or replace, at its own discretion and costs, the defective Product or parts or components of such Product reported to Truma and which Truma determines was defective due to a warranty defect. Costs of diagnosis for a warranty defect are borne by Truma. Other costs of diagnosis are not included in this warranty. At the discretion of Truma, the replacement of the Product or parts or components thereof (i) may be newly manufactured, (ii) may be assembled from new or serviceable used parts that are equivalent to new parts in performance, or (iii) may have been previously installed.

The customer shall not attempt to repair the Product or resolve the problem without the prior consent of Truma. Any attempt by the customer to repair the Product or resolve the problem without the prior consent of Truma will void this warranty.

This limited warranty does not cover any defects attributable in whole or in part to (i) non-Truma products and services and / or alterations of out-of-specification supplies, (ii) accidents, misuse, negligence or failure of the customer to follow instructions for the proper use, care and cleaning of the Product, (iii) damages caused in gas

pressure regulation systems due to foreign substances in the gas (i.e. oil, plasticizers), (iv) external factors (e.g., fire, flood, severe weather), (v) failure of proper transport packaging, or (vi) failure by the purchaser to comply with Truma's installation and user manual regarding the Product.

All warranty claims must be reported to Truma's authorized warranty service center in the United States:

Truma Corp Service Center,
825 East Jackson Blvd., Elkhart, IN 46516,
toll free: (855) 558-7862, fax. (574) 538-2426,
service@trumacorp.com, www.truma.net

The purchaser shall provide the following information regarding the potential warranty claim (i) serial number of the defective device, (ii) proof of purchase, (iii) purchaser's contact information.

EXCEPT AS EXPRESSLY STATED AND SET FORTH HEREIN, THERE ARE NO WARRANTIES OR REPRESENTATIONS, EXPRESS OR IMPLIED, CONCERNING THE PRODUCT AND NO SUCH WARRANTIES OR REPRESENTATIONS SHALL BE IMPLIED UNDER ANY APPLICABLE LAW, IN EQUITY OR OTHERWISE, INCLUDING WITHOUT LIMITATION, A WARRANTY OF MERCHANTABILITY, A WARRANTY OF FITNESS FOR A PARTICULAR PURPOSE, OR ANY OTHER WARRANTY WHICH MAY BE IMPLIED UNDER COMMON LAW OR UNDER THE UNIFORM COMMERCIAL CODE OF ANY STATE OR OTHER JURISDICTION OF THE UNITED STATES OF AMERICA.

Unless further limited herein, the entire liability of Truma and the customer's exclusive remedy for damages from any cause related to or arising out of a warranty defect, regardless of the form of action, whether in contract or in tort, will not exceed the amount of the purchase price for each purchase order for the Product which is the subject matter or directly related to the causes of action asserted.

Unless prohibited under applicable state law, in no event will Truma, its agents, subcontractors, affiliates, suppliers and employees be liable for (a) any incidental, indirect, special or consequential damages, including, but not limited to, loss of use, revenue, profits or savings, substitute rental or for any other reason, even if Truma knew or should have known of the possibility of such losses or damages, (b) claims, demands or actions against the customer by any person, except as provided by applicable law.

Maintenance and service

Repairs must be performed by a qualified service technician. Truma recommends that the Combi furnace be inspected annually by a qualified service technician.

⚠ WARNING

Danger of electrical shock, fire, scalding and/or explosion hazard!

Failure to follow safety warnings exactly and improper servicing could result in dangerous operation, serious injury, death or property damage.

- Before servicing, disconnect all electrical power to the Combi furnace.
- When servicing controls, label all wires prior to disconnecting. Reconnect wires correctly.
- Turn off the LP gas supply at the tank.
- Allow the Combi furnace to cool.
- Never actuate the pressure relief valve as long as the Combi furnace is under water pressure and/or still warm.
- Verify proper operation after servicing.

⚠ CAUTION

Danger of injuries due to sharp edges!

- Always wear protective gloves to avoid injuries from sharp edges during maintenance work.

There are no serviceable parts inside.

In case of a defect please contact the Truma Service Center on 1-855-558-7862 or one of our authorized service partners to replace the complete furnace.

For details see www.truma.net.

Decalcifying and cleaning the water container

i Truma recommends decalcifying and cleaning the water container at least twice a year for hygienic reasons. Only use specialized and suitable products. Do not use chlorine-based products. Read and follow the instructions of the decalcifying agent's manufacturer.

1. For decalcifying the water container, fill the water container with citric acid and let it work for some time.
2. Fill citric acid into the fresh water supply and dilute it with fresh water according to the supplier's specification.
3. Add more than 2.64 gallons (10 liters) of water to fill up the water container of the Combi furnace.
4. Drain the mixture of citric acid and water from the water container (refer to "Draining the water container" on page 13) and flush it with fresh water (refer to "Filling the water container" on page 12).

i In order to avoid growth of micro-organisms, regularly heat the water in the boiler to 158 °F (70 °C) as follows:

- Select energy mode "LP gas" on CP plus control panel.
- Select the hot water level "boost" on CP plus control panel.
- When the water temperature is reached (the display does not flash anymore), leave the heating switched on for another 30 minutes without withdrawing water from the system. The residual heat in the device will heat the water to up to 158 °F (70 °C).

Truma pressure relief/drain valve

▲ WARNING

Risk of scalding injury from hot water and/or tampering with the pressure relief/drain valve!

- Never actuate the lever as long as the Combi furnace is under water pressure and/or still hot.
- Do not place a plug or reducing coupling on the outlet part of the valve. If you use a discharge line, allow the valve and the line to drain completely.

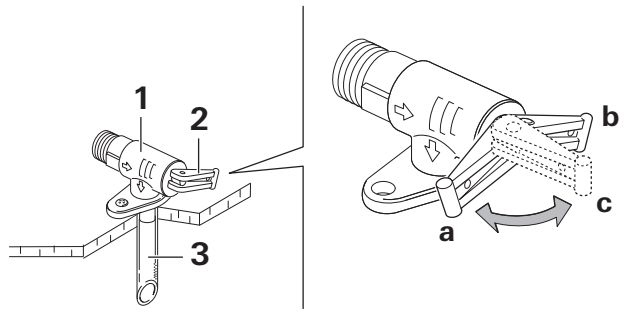

Fig. 7

- a,b = lever in "valve closed during furnace operation" position
- c = lever in "draining" position



- The Truma pressure relief/drain valve provides both the pressure relief function and a drain function.
- The pressure relief/drain valve is a safety component and must not be removed for any reason other than replacement.
- The pressure relief/drain valve is not serviceable; if defective, it must be replaced. It must be replaced by a certified service technician.
- It must only be replaced by the Truma pressure relief/drain valve rated for 65.25 psi (4.5 bar) which is CSA certified and registered.
- Tampering with the pressure relief/drain valve will void the warranty.
- Operate the valve manually at least once per year to ensure that water channels are clear.
- Before lifting the lever (Fig. 7 – 2), make sure that the discharge line is securely attached and properly installed, to prevent injury and property damage.
- If no water flows when the lever is operated, check the water supply.
 - The water pump must be turned on or the RV must be connected to city water.
- The pressure relief/drain valve should be inspected every three years by a qualified service technician and be replaced if necessary.

Replacing the 12-volt fuse

Only a qualified service technician may perform this task.

The fuse is on the printed circuit board underneath the connection cover.

- While detaching or reattaching the connection cover (Fig. 8 – 5), take care to neither dislodge nor pinch the connector cables.
- A defective fuse must be replaced with the same make and model of fuse.

10 AT time-lag, 5 X 20 mm. IEC 60127-2 Standard

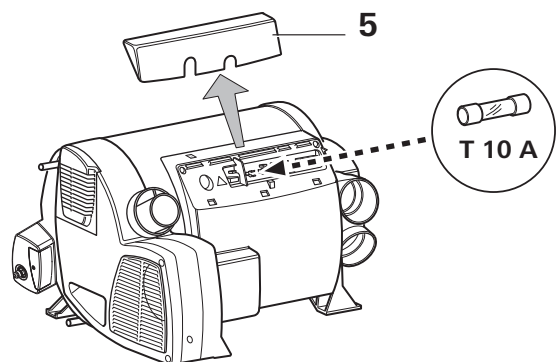

Fig. 8

Troubleshooting

i Faults occurring during operation of the Combi furnace are displayed as an error code on the CP plus control panel (refer to the Troubleshooting section in the CP plus manual for additional instructions). The potential cause as well as a solution is described according to the error code in the CP plus manual.

The potential causes for problems with the water system and the Combi furnace are described below:

Problem	Potential cause	Solution
Water heats up too slowly.	Lime scale (hard water calcification) in the water container.	Decalcify the water container (refer to "Decalcifying and cleaning the water container" on page 17).
Water drains. / The hot water container cannot be refilled.	The pressure relief/drain valve is open.	Close the pressure relief/drain valve.
The water container cannot be emptied even though the pressure relief/drain valve is open.	The drainage socket of the pressure relief/drain valve is obstructed.	Remove any obstructions such as slush, ice, or leaves from the opening of the drainage socket. Make sure that the faucets are opened in the position "hot".
Water is dripping / flowing from the drainage socket of the pressure relief/drain valve.	Water pressure in the water system is too high.	Check the pump pressure and adjust if necessary. Replace the water pump if an adjustment is not possible.
		Ensure that a pressure reducer is installed on your city water connection, not exceeding 40.6 psi (2.8 bar).
	The pressure inside the water container rises above a water pressure of approx. 65,25 psi (4.5 bar) – Truma pressure relief/drain valve installed.	The Truma pressure relief/drain valve protects the water container against a pressure greater than 65,25 psi (4.5 bar). This is not a fault. If the condition continues, contact Truma service.
	Water pressure in the water system is too high.	Replace the water pressure reducer at the fresh water supply. This must be performed only by a qualified service technician.
	Lime or dirt under the pressure relief/drain valve seat.	Rinse the pressure relief/drain valve to remove contamination from the valve seat (refer to "Draining the water container" on page 13). Replace the pressure relief/drain valve. This must be performed only by a qualified service technician.

If none of the measures in the troubleshooting chart proves successful, please contact your dealer, the Truma Service Center on 1-855-558-7862 or one of our authorized service partners.

Appendix

The following pictures show the labels on the Combi furnace. If any of the labels are missing or unreadable, please contact the Truma Service Center on 1-855-558-7862.

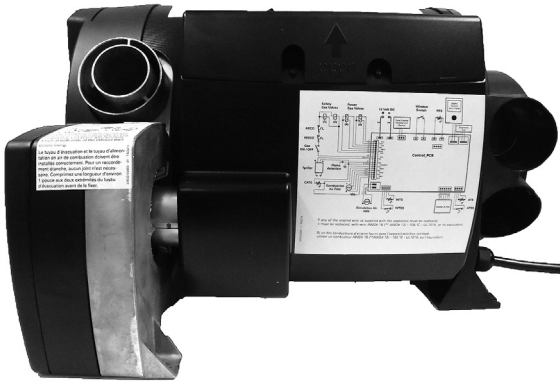

Fig. 9



Fig. 10



Fig. 11



Fig. 12

This page is intentionally left blank.

This page is intentionally left blank.

This page is intentionally left blank.

USA In case you encounter any problems,
please contact the Truma Service Center
at 855-558-7862 or one of our authorized
service partners. For details see
www.truma.net.

Please have the model number and serial
number (on furnace's type plate) handy
when you call.

Truma reserves the right to make technical modifications

Manufacturing

Truma Gerätetechnik GmbH & Co. KG
Wernher-von-Braun-Straße 12
85640 Putzbrunn
Germany
www.truma.com

Sales

Truma Corp
825 East Jackson Blvd.
Elkhart, IN 46516
USA
Toll Free 1-855-558-7862
Fax 1-574-538-2426
service@trumacorp.com
www.truma.net